

ROHS

REV.	ECO NO.	DATE	SIGN	DESCRIPTION
A		20130820		NEW DRAWING

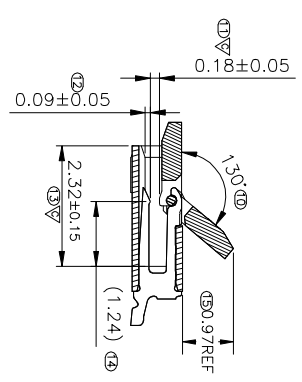

NOTES:
 1. MATERIAL:
 HOUSING: HIGH-TEMP PLASTIC, UL 94-V0, COLOR: WHITE;
 COVER: HIGH-TEMP PLASTIC, UL 94-V0, COLOR: BROWN;
 CONTACT: COPPER ALLOY;
 LEG: COPPER ALLOY;
 2. PLATING:
 CONTACT: GOLD OR TIN PLATED ON NICKEL OVERALL.
 LEG: TIN PLATED ON NICKEL OVERALL.
 3. RATING:
 CURRENT RATING: 0.4A AC/DC
 VOLTAGE RATING: 50V AC/DC
 TEMPERATURE RANGE: -55°C~+85°C;

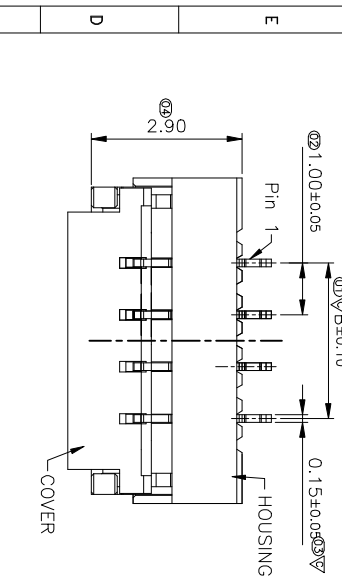
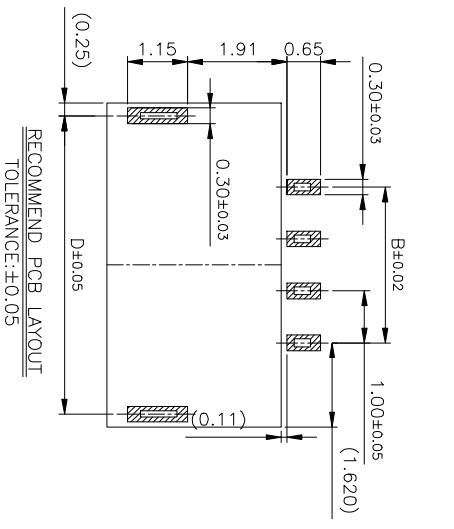
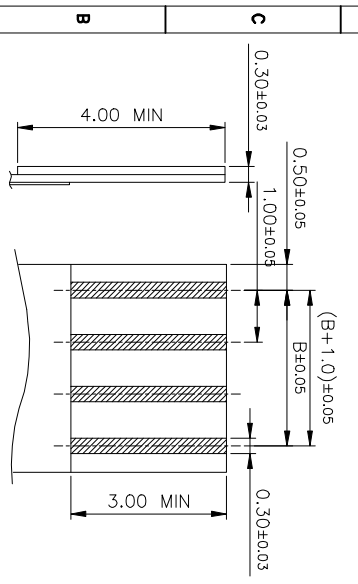
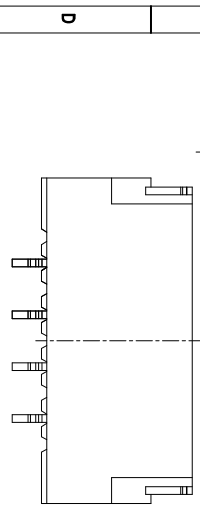
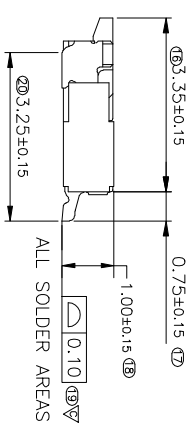
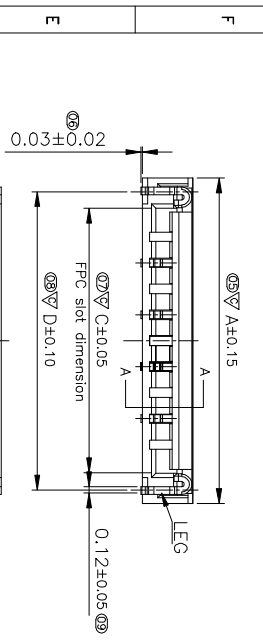

PIN NO.	DIM. A	DIM. B	DIM. C	DIM. D	PIN NO.	DIM. A	DIM. B	DIM. C	DIM. D
04	6.27	3.00	5.10	5.74	23	25.27	22.00	24.10	24.74
05	7.27	4.00	6.10	6.74	24	26.27	23.00	25.10	25.74
06	8.27	5.00	7.10	7.74	25	27.27	24.00	26.10	26.74
07	9.27	6.00	8.10	8.74	26	28.27	25.00	27.10	27.74
08	10.27	7.00	9.10	9.74	27	29.27	26.00	28.10	28.74
09	11.27	8.00	10.10	10.74	28	30.27	27.00	29.10	29.74
10	12.27	9.00	11.10	11.74	29	31.27	28.00	30.10	30.74
11	13.27	10.00	12.10	12.74	30	32.27	29.00	31.10	31.74
12	14.27	11.00	13.10	13.74					
13	15.27	12.00	14.10	14.74					
14	16.27	13.00	15.10	15.74					
15	17.27	14.00	16.10	16.74					
16	18.27	15.00	17.10	17.74					
17	19.27	16.00	18.10	18.74					
18	20.27	17.00	19.10	19.74					
19	21.27	18.00	20.10	20.74					
20	22.27	19.00	21.10	21.74					
21	23.27	20.00	22.10	22.74					
22	24.27	21.00	23.10	23.74					

Applicable FPC

TOLERANCE UNLESS SPECIFIED	DATE 20130820	DAR. BY	MATERIAL
LINEAR	SCALE 1/1	CHK. BY	FINISH
.X ±0.25			
.XX ±0.15	UNIT mm	APP. BY	PART NO.
.XXX ±0.10			

深圳市迈瑞康电子有限公司

TITLE: FPC 1.0Pitch 1.0H掀盖式 connector 0.3间距线

DWG NO. MKK-FPC01-110-0023

REV. A