

符合ROHS环保要求

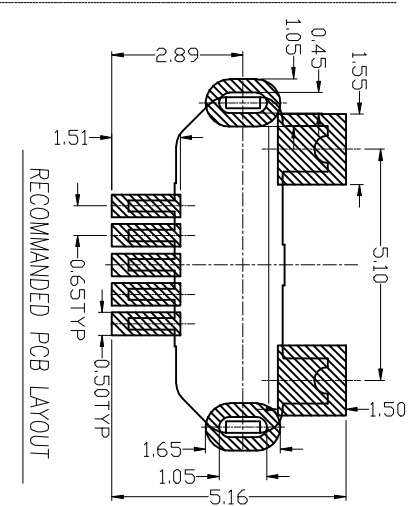
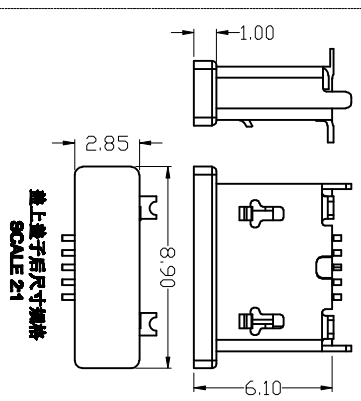
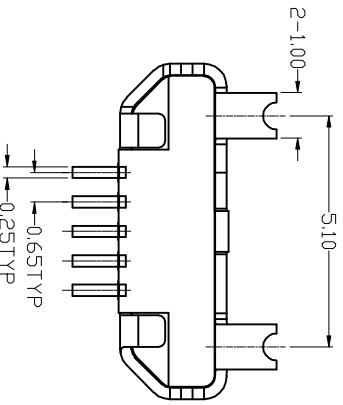
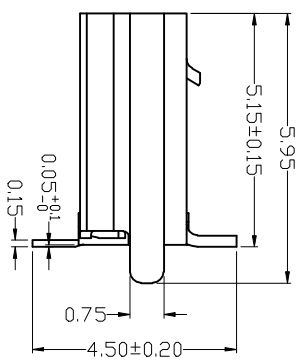
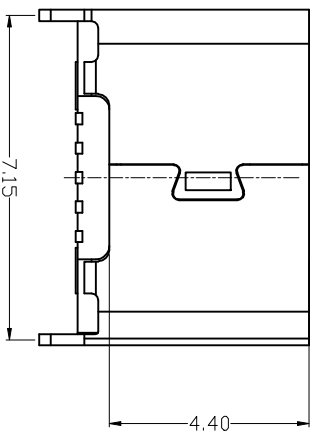
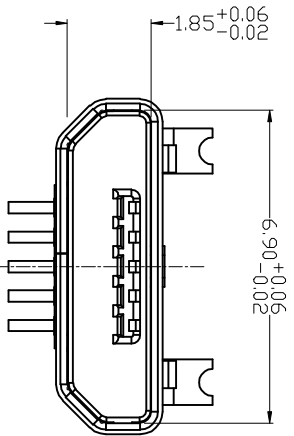
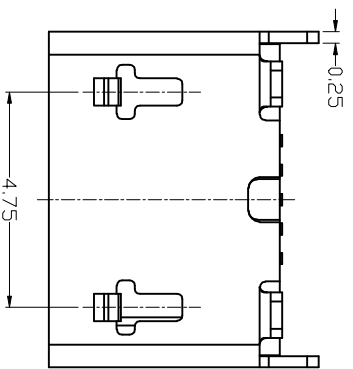

PCB LAYOUT

物料序号 A/0	物料规格	名称	日期
-------------	------	----	----

深圳市迈睿康科技有限公司

图纸名称:

MICRO SP/F B 180度立式SMT贴片无边带后盖

TOLERANCE	.000 ±0.05
	.00 ±0.10
	.0 ±0.25
ANGLE	1°

产品料号: MRK-MU33-510-0048

比例: 1:1
单位: mm

审核: WCY

设计:

版本号: A/0

Note:

- Material:
 - Housing: High temperature thermoplastic with g.f.,UL94V-0
 - Contact: copper alloy,t=0.15mm
 - Shell: copper alloy/SUS
- Specification:
 - Current rating: 1 A Max.
 - Dielectric withstanding voltage: 100 V(ac) for 1 min.
 - Contact resistance: 30 mΩ Max.
 - Insulation resistance: 100 MΩ Min.
 - Total mating force: 3.57 Kgf Max.
 - Total unmating force: 1.0 Kgf Min,0.81~2.05 Kgf Min,after 10000 insertion/extraction cycles
 - Temperature range: -30C~80C